

BYCOPLUS/SPORT

PATENTED PRODUCT | DESIGNED AND BUILT IN ITALY

- ▶ FOLDING SCOOTER
- ▶ DETACHABLE

BYCOPLUS is composed of three independent portions each weighing lesser than ten kilograms. It's easy to fold up on itself and - if necessary - it can be completely disassembled into several parts really handy that allow you to put the vehicle in the boot of the car or in the practical travel bag. It is equipped with KERS controller for the optimization of energy consumption.

ACCESSORIES ON REQUEST

- BACK FOR LARGE SEAT
- HEADLIGHT
- REAR LIGHT
- REAR-VIEW MIRROR
- HOLDER FOR CRUTCHES & WALKING STICK
- REAR BASKET
- REAR TRAILER
- TRAVEL BAG WITH WHEELS

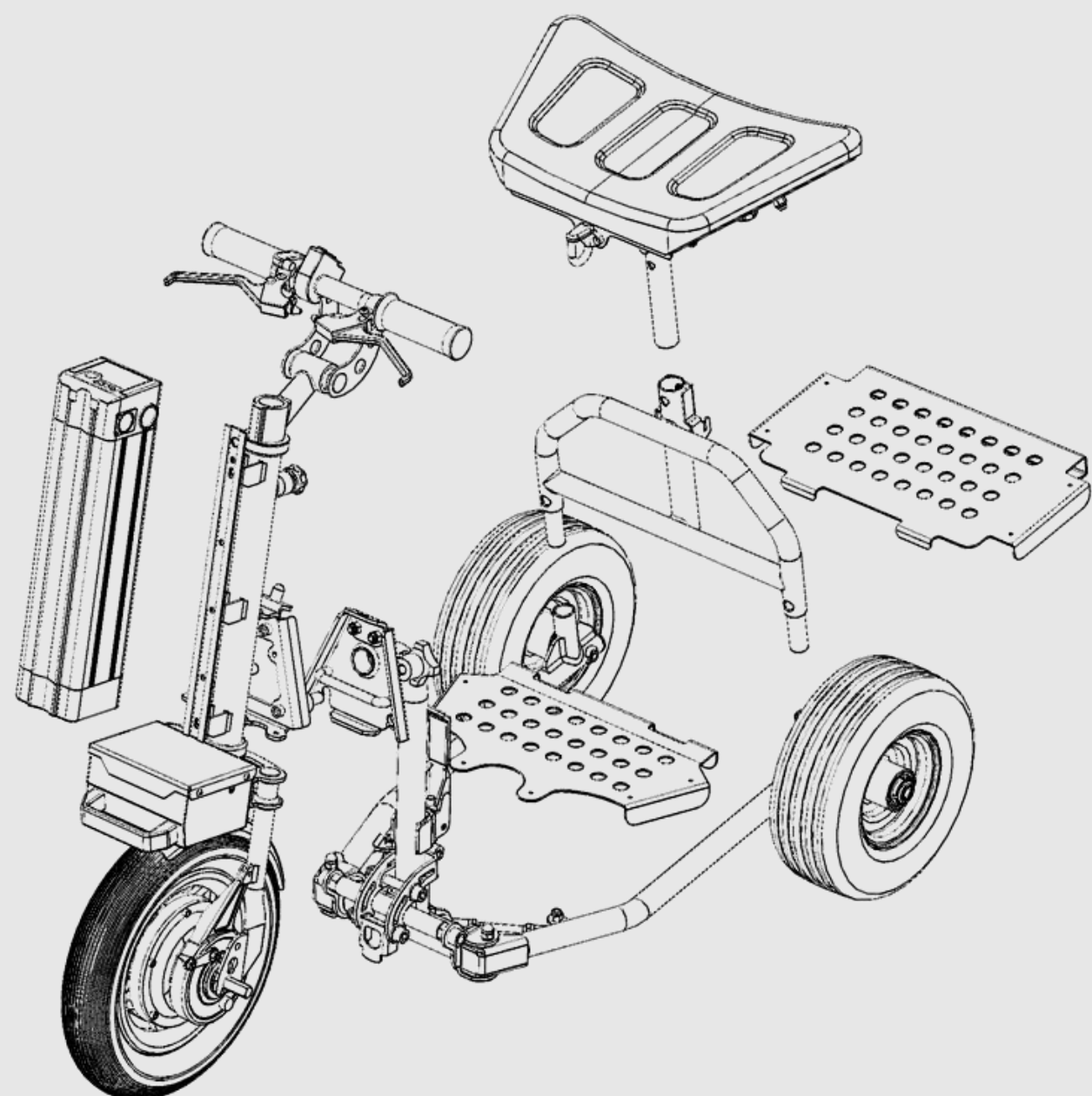

FOLDING / DISASSEMBLY

WITHOUT USING ANY TOOL

- MOTOR (*)**
- CONTROLLER**
- GEAR**
- SPEED**
- ▶ **PUBLIC PLACES**
- ▶ **PRIVATE PLACES**
- OPERATING RANGE**
- TYPE BATTERY**
- BATTERY CHARGER**
- TURNING RADIUS**
- GRADIENT**
- CARRYING CAPACITY**
- BRAKE**
- FRONT WHEELS**
- REAR WHEELS**
- HANDLEBAR**
- WEIGHT**
- DIMENSIONS**
- ▶ **OPEN**
- ▶ **FOLDED**

- BRUSHELESS 36 Volt 250 Watt
- MOSFET 36 Volt AUTO PROTECTED
- FORWARD - REVERSE
- 6 Km/h - PRESET
- 20 Km/h - ACTIVATED MANUALLY
- 20 Km - ON FLAT GROUND WITH AN 80kg PAYLOAD
- LITHIUM 36 Volt - 10 A/h - WEIGH 4 KG
- WITH INDICATOR OF CHARGE
- 2 Amp - CHARGING TIME 6 hours - 220 Volt
- 45 cm
- 12% MAXIMUM
- 130 Kg
- BRAKE DRUM WITH PARKING FUNCTION
- 305x70 mm - INFLATABLE
- 305x100 mm - INFLATABLES - 4ply
- REGOLABLE AND INCLINABLE
- 30 Kg - TOTAL WITHOUT BATTERY
- 34 Kg - TOTAL WITH BATTERY

SPECIAL VERSION

BYCOPLUS is also available in a SPORT version with (*)
MOTORE 36 Volt - 350 Watt

COMMERCIAL INFORMATION

Code CND	Y122130
Code RDM	1233514/R
Code ISO	12.21.27.006

Declaration of conformity attached to the manual



meccanica **BERTAZZONI**
di Alberto Bertazzoni

via XXV aprile 9 - 42044
GUALTIERI (RE) - ITALY

Tel +39 0522 828590
Fax +39 0522 220241
Info bertazzoni@bertazzoni.it
Web www.bertazzoni.it

Partita IVA: 01248750356
Codice Fiscale: BRTLRT47M14E253E